

iArmor[®]

iArmor[®] by APS

PART#: IA-S208&S209

BEFORE INSTALLATION

REMOVE CONTENTS FROM BOX. VERIFY ALL PARTS ARE PRESENT. READ INSTRUCTIONS CAREFULLY BEFORE STARTING INSTALLATION. ASSISTANCE IS RECOMMENDED. THANK YOU FOR CHOOSING OUR PRODUCT!

Fastener Size	Tightening Torque (ft-lbs)
6mm	6-7
8mm	16-18
10mm	31-32
12mm	56-58
14mm	92-94

PART LIST

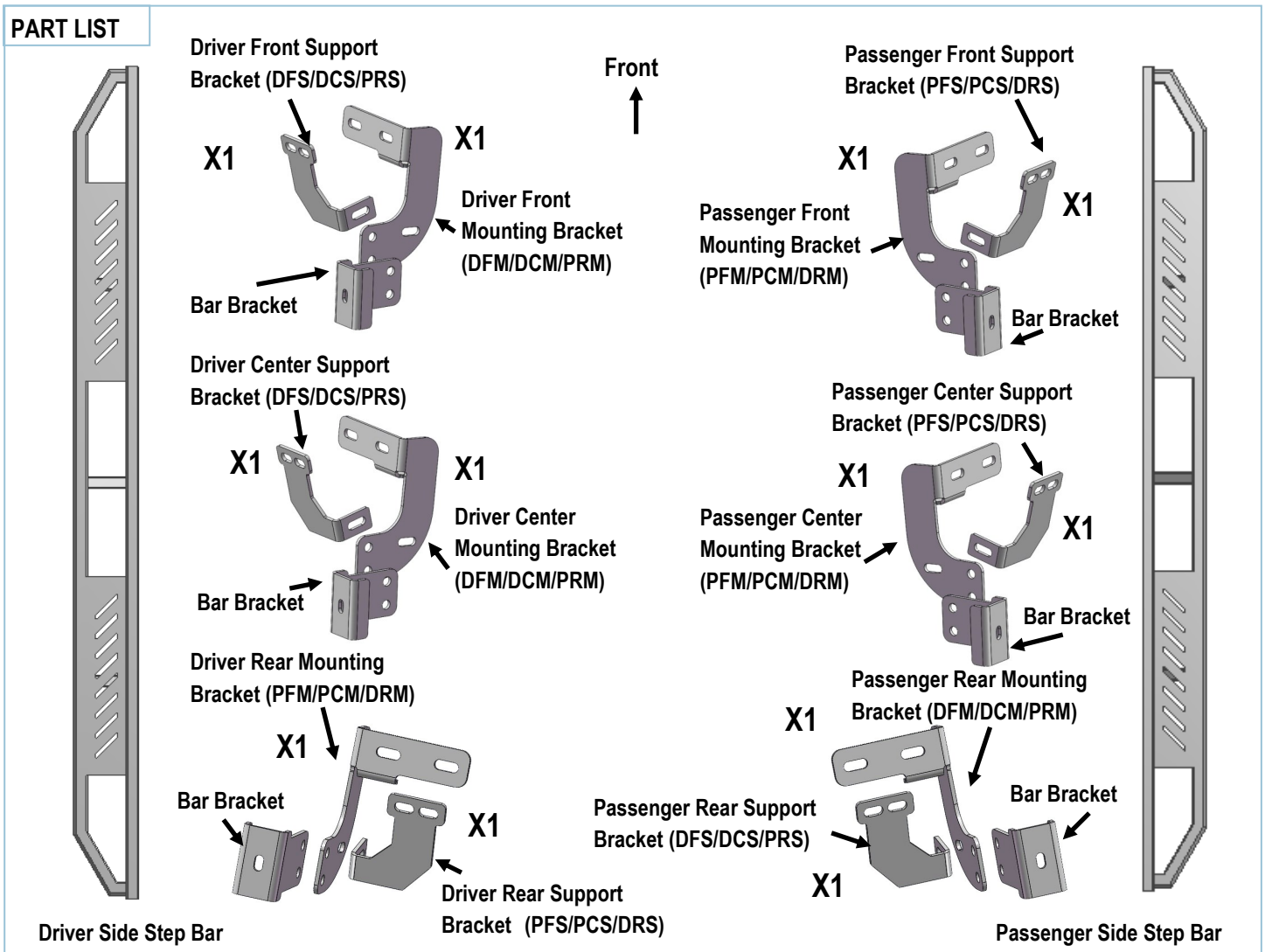

Customer Support: info@iarmorauto.com

iArmor®



The instruction here is for your reference only. We strongly recommend the professional installer for best result. We are not responsible for any damage caused by the installation.

STEP 1

Starting at the driver side front of the vehicle, remove the sealing tape covering the factory holes in the side of the inner panel, (Fig1).

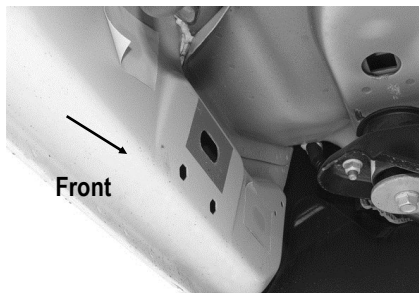

(Fig 1) 2009-Mid 2015 Driver Front Mounting Location (No Factory Holes In Pinch Weld 2009-2011 Models)

STEP 2

Determine the correct procedure to attach one driver side Bracket for your model/year:

Models without factory threaded inserts in body panel:

- Select (1) M8 x1.25-30mm Nut/Bolt Plate, (Fig 2). Partially thread the Hex Bolt into the threaded end until it is flush with the welded nut, (Fig 3). Use the Hex Bolt as a handle and insert the Nut/Bolt Plate into the oval hole, (Fig 4). Feed the threaded bolt on the Bolt Plate through one of the hex shaped factory holes. Thread (1) M8 Plastic Washer onto the threaded end and down tight against the body panel, (Fig 5). **NOTE:** The Plastic Washer is designed to keep the Nut/Bolt Plate from falling into the body panel and to aid in Bracket installation.
- Assemble Driver Front Mounting Bracket (DFM/DCM/PRM) and Bar Bracket with (2) M10X1.5-25mm Hex Bolts, (2) M10 Flat Washers and (2) M10X1.5 Hex Flange Nuts (Fig 6a). Attach the Assembled Bracket to the Bolt end of the Bolt Plate with (1) M8 Large Flat Washer, (1) M8 Lock Washer and (1) M8 Hex Nut, (Fig 6b). Do not fully tighten

at this time.

- c. Remove the M8X1.25-30mm Hex Bolts from the nut on the Bolt Plate from **Step 2a**. Rotate the Bolt on the Bolt Plate until the threaded nut lines up with the remaining hole in the Mounting Bracket and body panel, (**Fig 6b**). Attach the Bracket to the threaded Nut Plate with (1) M8X1.25-30mm Hex Bolts, (1) M8 Lock Washer and (1) M8 Large Flat Washer, (**Fig 6c**). Do not fully tighten hardware at this time.

Models with factory threaded inserts:

Assemble Driver Front Mounting Bracket and Bar Bracket (**Fig 6a**). Attach the Assembled Driver Front Mounting Bracket to the threaded inserts with (2) M8X1.25-30mm Hex Bolts, (2) M8 Lock Washers and (2) M8 Large Flat Washer, (**Figs 7 & 8**). Leave hardware loose.



(Fig 2) M8 Nut/Bolt Plate, NOTE: M8 Nut/Bolt Plate Is Not Required On Models With Threaded Inserts



(Fig 3) Thread (1) M8 Hex Bolt Into The Nut On The Plate. Stop When Bolt Reaches End Of Nut As Pictured

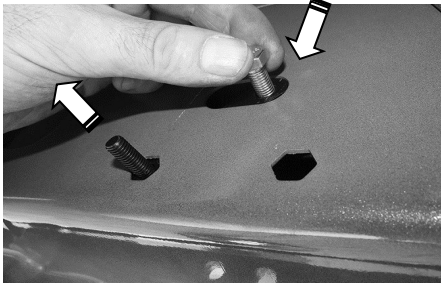

(Fig 4) Use The Loose Hex Bolt As A Handle. Insert The M8 Nut/Bolt Plate Into The Oval Hole And Feed The Threaded End Out Either Factory Hex Shaped Hole. IMPORTANT: Do Not Let Go Of The Hex Bolt Until After Plastic Retainer Has Been Threaded Onto Bolt (Fig 5)

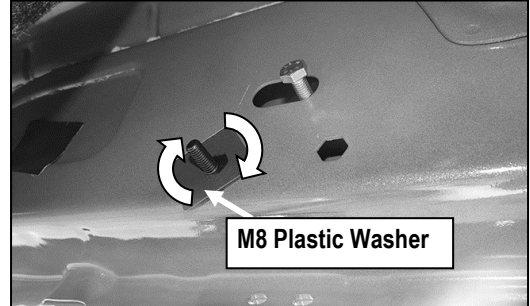

(Fig 5) Thread Plastic Washer Onto M8 Nut/Bolt Plate To Hold Nut/Bolt Plate In Position.

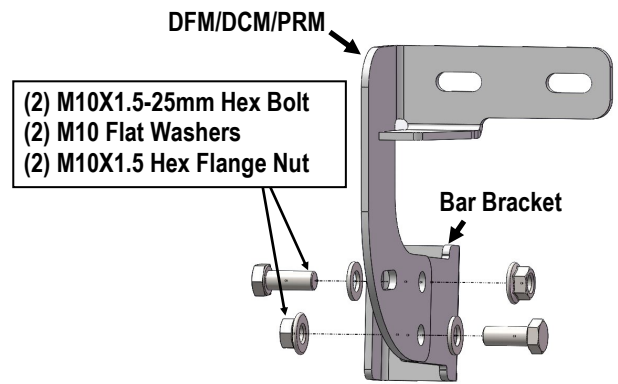

(Fig 6a) Driver Front Mounting Bracket (DFM/DCM/PRM) And Bar Bracket Assembly

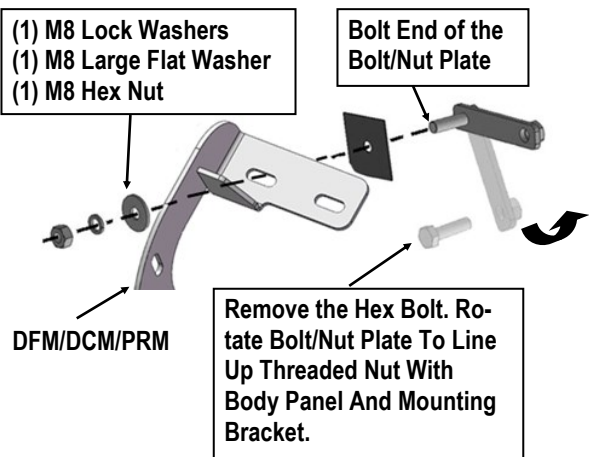

(Fig 6b) Attach Bracket to Bolt end of the Bolt/Nut Plate

iArmor®

STEP 3

Next, select a Driver Front Support Bracket (**DFS/DCS/DRS**). Attach the Bracket to the front facing side of the front Bracket with (1) M8X1.25-30mm Hex Bolt, (2) M8 Large Flat Washers and (1) M8X1.25 Nylon Lock Nut, (**Fig 9**). Rotate the Support Bracket to the back of the pinch weld. Line up the slots in the top of the Support Bracket with the (2) factory holes in the pinch weld. Attach the Bracket to the back of the pinch weld with (2) M6X1-25mm Hex Bolts, (4) M6 Large Flat Washers and (2) M6X1 Nylon Lock Nuts, (**Figs 10 & 11**). Do not fully tighten hardware at this time. **IMPORTANT:** Some models are not equipped with factory holes and will require drilling through the pinch weld to attach the Support Bracket. Do not drill through pinch weld at this time.

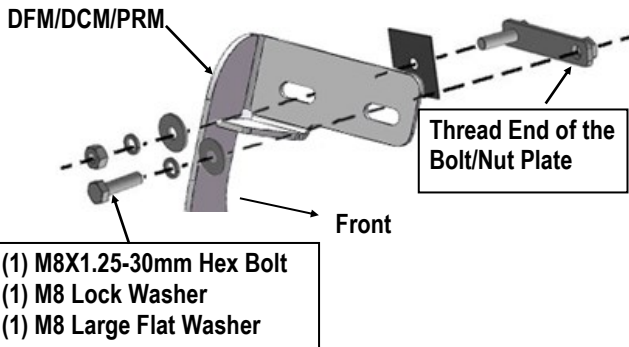

(Fig 6c) Attach the Bracket to Threaded End of the Bolt/Nut Plate

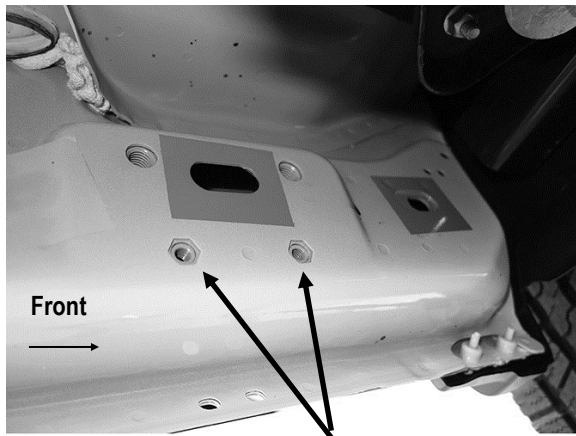

(Fig 7) Driver Side Front Mounting Location (Mid 2015-On, An Example Of Models With Factory Installed Threaded Inserts)

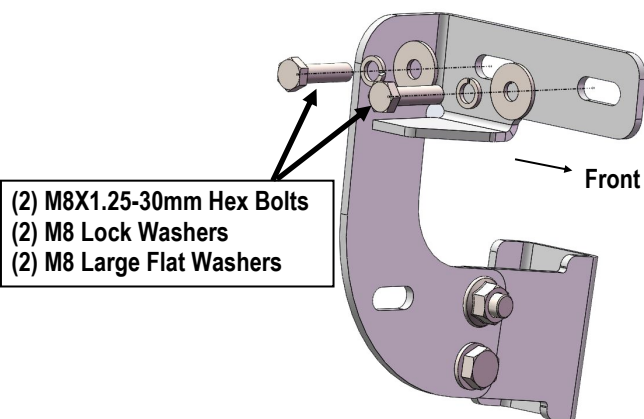

(Fig 8) The Assembled Driver Front Mounting Bracket Installed (For Models With Factory Installed Threaded Inserts. Bolt Plate Not Required)

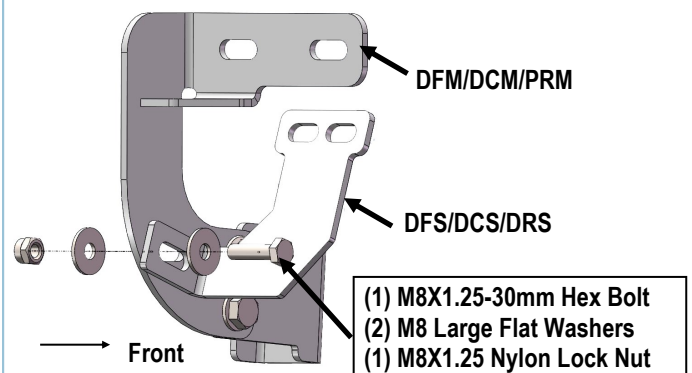

(Fig 9) Attach Driver Front Support Bracket to the Driver Front Mounting Bracket

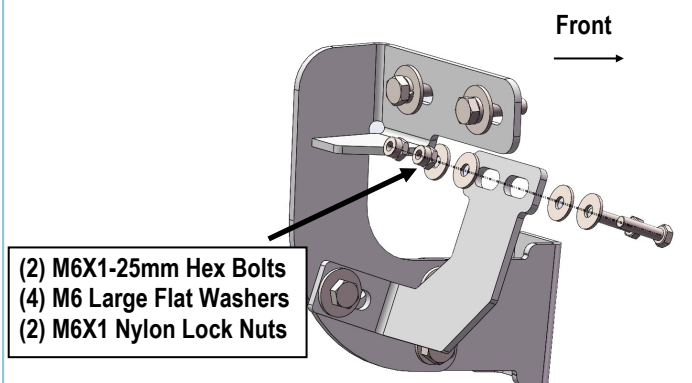

(Fig 10) Attach Support Bracket to the Back of Pinch Weld (Some Models May Require to Drill Holes on Pinch Weld)

iArmor®

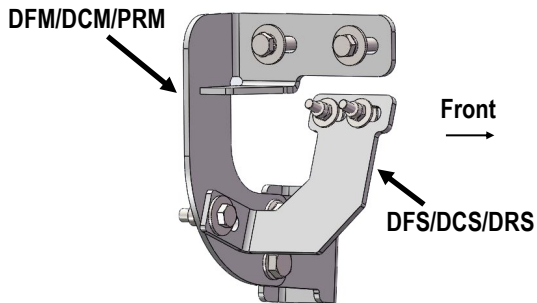

(Fig 11) Driver Side Front Brackets Installed

STEP 4

Move along the side of the body panel to the center and rear mounting location, (Figs 12 & 13). Repeat Steps 2-3 to install the driver side center & rear Brackets, (Fig 14).

IMPORTANT: The front and center driver side Brackets are universal.

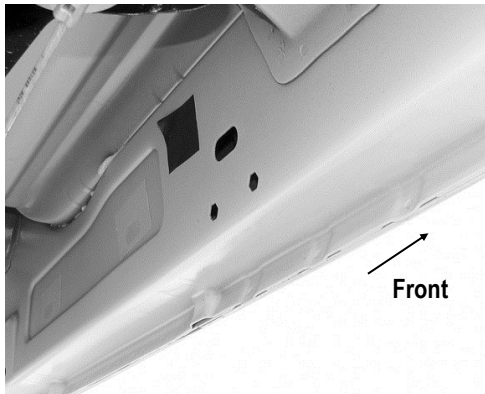

(Fig 12) Driver Side Center Mounting Location

IMPORTANT:

Some models without holes in pinch weld will require drilling 1/4" holes through pinch weld to attach driver side front support bracket. Do complete installation of the Driver Side Bar first, level board before drilling holes for support bracket.

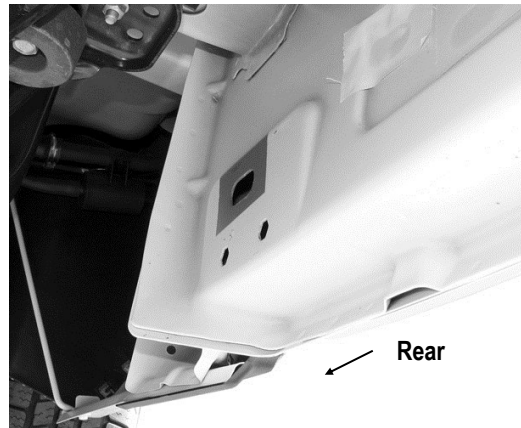

(Fig 13) Driver Side Rear Mounting Location

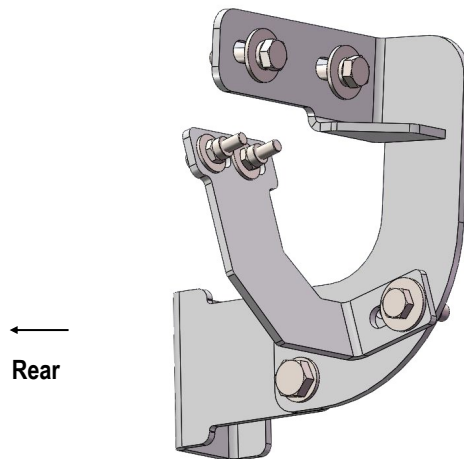

(Fig 14) Driver Side Center /Rear Brackets Installed

STEP 5

Once all (3) driver side mounting brackets are installed, select and attach the Driver Side Step Bar onto the Mounting Brackets with (3) U Brackets, (6) Spacers, (3) M8X1.25-55mm Carriage Bolts, (3) M8 Large Flat Washers, (3) M8 Lock Washers and (3) M8X1.25 Hex Nuts (Fig 15). Do not fully tighten hardware at this time. Properly level and adjust the Step Bar and fully tighten all hardware.

iArmor®

NOTE: Torque all M8 X1.25-55mm Carriage Bolts to 16~18 lb-ft. Don't over tighten, or the aluminum square bars will be damaged by the brackets

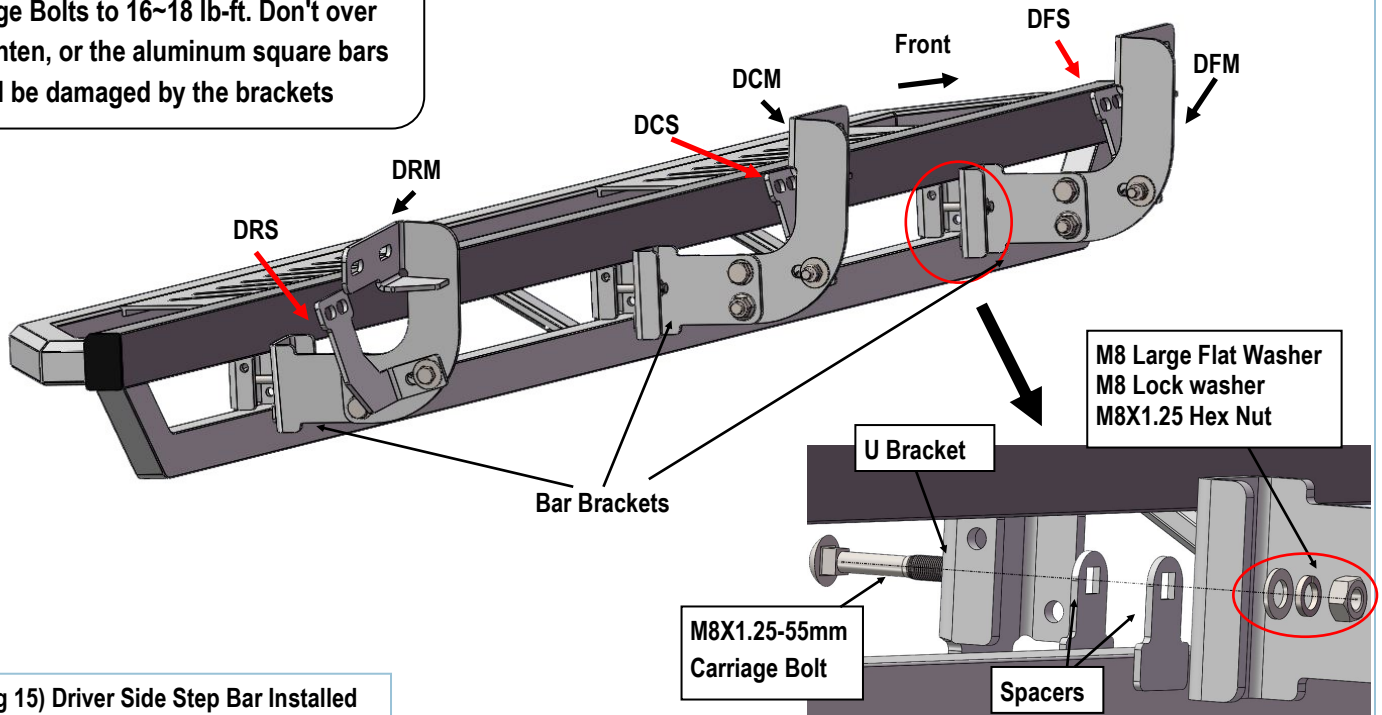

(Fig 15) Driver Side Step Bar Installed

STEP 6

Properly level and adjust the Step Bar and fully tighten all hardware.

STEP 7

Move to the passenger side of the vehicle. Repeat **Steps 1-6** to install passenger side step bar.

Installation completed (Fig 16).



(Fig 16) Installation Completed

Attention

Do periodic inspections to the installation to make sure that all hardware is secure and tight.

In order to protect your bars/boards, please use only mild soap/non-abrasive products for cleaning.